

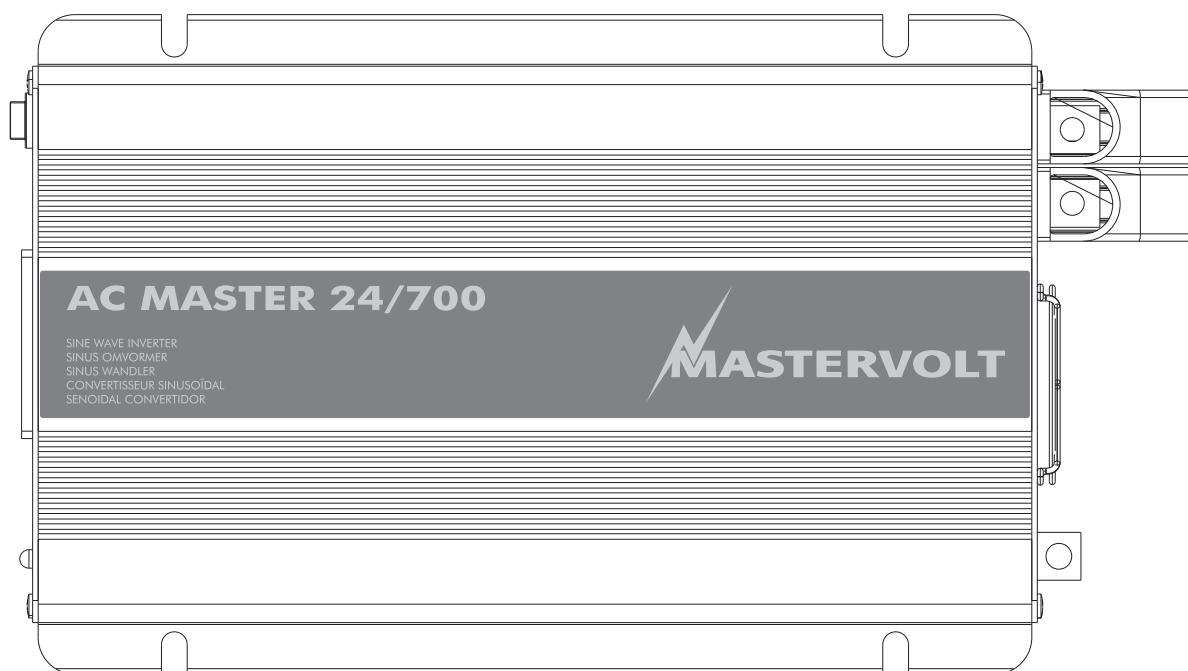

USERS MANUAL / GEBRUIKERSHANDLEIDING / MANUAL DE UTILIZACION

AC Master 12/700 & 24/700

Switch mode sine wave inverter



MASTERVOLT
Snijdersbergweg 93, 1105 AN Amsterdam
The Netherlands
Tel.: +31-20-342 21 00
Fax: +31-20-697 10 06
www.mastervolt.com

ENGLISH:	PAGE 1
NEDERLANDS:	PAGINA 9
CASTELLANO:	PÁGINA 17

v 1.0 January 2008

1



This section provides a brief overview of a basic stand alone installation of the AC Master

However; please review the entire manual for connection of additional features and to ensure best performance and years of trouble-free operation.



Use isolated tools!
Read safety instructions (page 3)

2

Disconnect the electrical power:

- Switch off all consumers,
- Switch off all charging systems.
- Remove the battery fuse.
- Check with a suitable voltmeter whether the DC installation is voltage free.

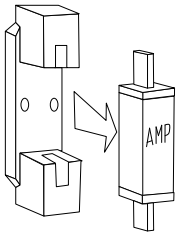

3

Move the main switch of the AC Master to the **OFF position**

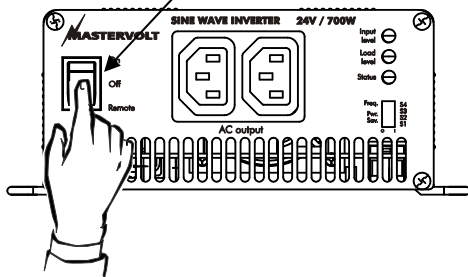

4

Mount the AC Master with four screws to a solid surface. Allow at least 10 cm / 4 inch space around the apparatus!

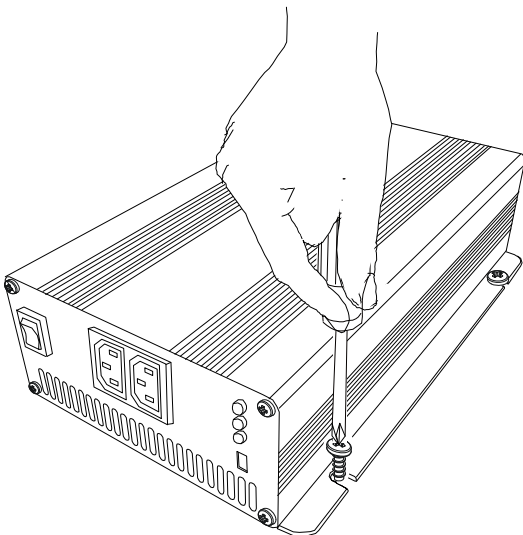

5

Connect the battery to the DC input. Integrate a fuse holder in the positive battery wire, but do not place the fuse yet.

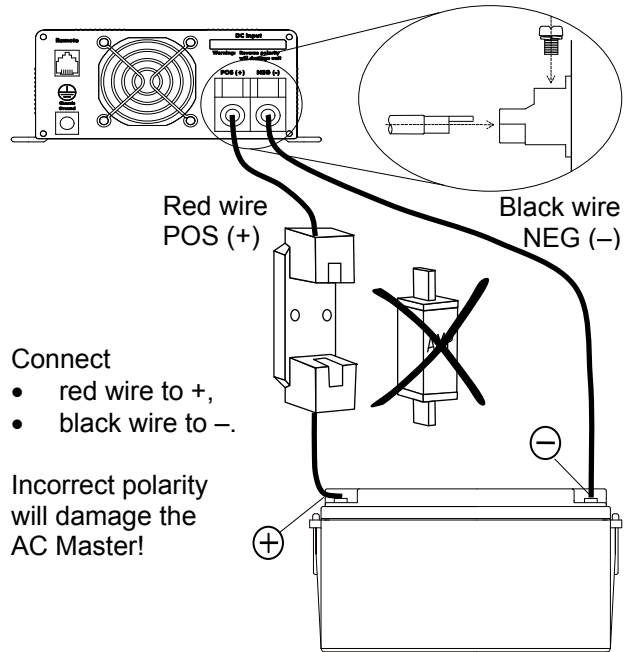

Connect

- red wire to +,
- black wire to -.

Incorrect polarity will damage the AC Master!

6

The AC load can be connected directly to the AC socket.

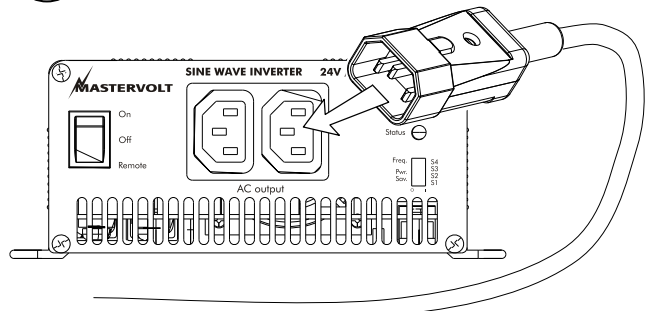

For safe installation:

- Connect the grounding point of the AC Master to the central grounding point of the vehicle/ship.
 - If you need to install a Residual Current Device (RCD) in the wiring of the AC output, both the earth (PE/GND) and the neutral (N) of the AC output of the AC Master must be connected to the grounding point
- Refer to local applicable regulations on these issues.

7

Check all wiring. If all wiring is OK:

- Place the inverter fuse.
- Switch on the AC Master.

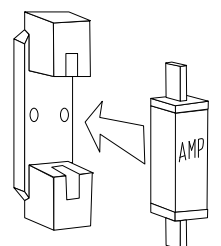

PRODUCT DESCRIPTION AND APPLICATION

The Mastervolt inverter “AC Master” converts a DC voltage to a pure AC sine wave voltage.

SAFETY INSTRUCTIONS



WARNING!

Before using the AC Master, read and save the safety instructions

- Use the AC Master in accordance with the instructions and specifications stated in this manual.
- Connections and safety features must be executed according to the locally applicable regulations
- Operation of the AC Master without proper grounding may lead to hazardous situations!
- Use DC-cables with an appropriate size. Integrate a fuse in the positive wiring and place it nearby the battery. Refer to the specifications.
- If the positive and negative wires on the DC-input (battery) are exchanged, the AC Master will be damaged. Damage of this kind is not covered by guarantee. Check whether all connections are connected correctly before placing the fuse.
- Do not connect the AC-output of the inverter to an incoming AC source.
- Never connect the AC Master in parallel with any other inverter.
- Never open the housing as high voltages may be present inside!

UNPACKING

The delivery consists of the following parts:

- The AC Master
 - This user's manual
 - Four ring terminals
 - 1m/3ft AC-lead with IEC320-plug
- After unpacking, check the AC Master for possible damage. Do not use the AC Master if it is damaged. If in doubt, contact your supplier.

DIP SWITCH SETTINGS

Under normal circumstances there is no need to change the default settings of the DIP switches: the inverter is immediately ready for use.

See figure 1. On the front side of the inverter four DIP switches (ref. 6) can be found to adjust the inverter in accordance with your personal preferences.

To save energy from the battery in no load operation, DIP switches S1, S2 and S3 can be used to adjust the Power Saving Mode. The Power Saving Mode scans the output and when it detects a load which is higher than the selected threshold value, the inverter is switched on automatically.

Power Saving Mode	S1	S2	S3
DISABLE	0	0	0
15W	1	0	0
30W	0	1	0
40W	1	1	0
56W	0	0	1
70W	1	0	1
84W	0	1	1
100W	1	1	1

DIP switch S4 is used to select the output frequency

Output frequency	S4
50Hz	0
60Hz	1

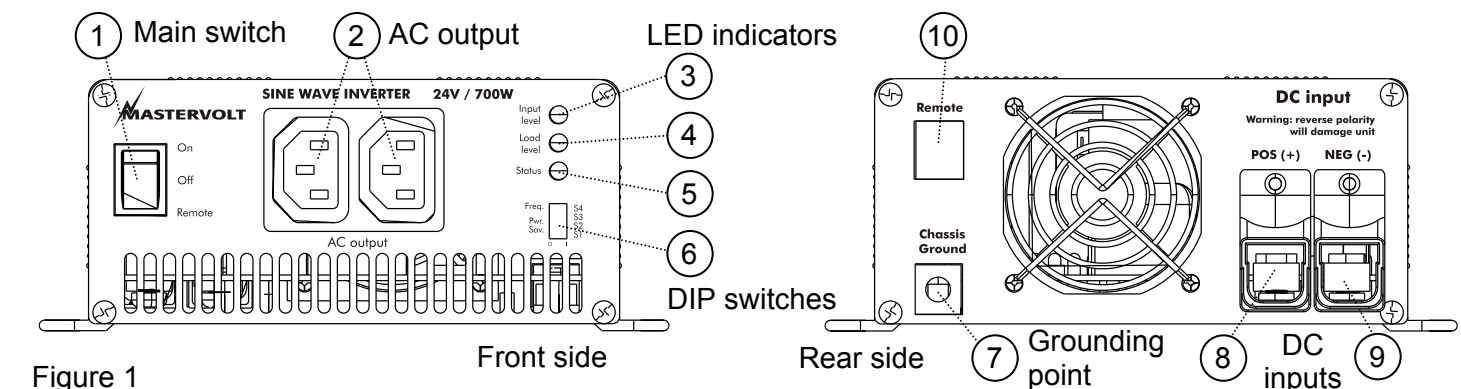

Figure 1

INSTALLATION

Choosing a location to install

- Install the AC Master in a well-ventilated room protected against rain, vapour, moisture and dust.
- Ambient temperature: $-25 \dots 40^{\circ}\text{C}$ / $-13 \dots 104^{\circ}\text{F}$;
- Never use the AC Master at a location where there is danger of gas or dust explosions
- Mount the AC Master in such a way that obstruction of the airflow through the ventilation openings is prevented. No objects must be located within a distance of 10 cm / 4 inch around the AC Master.
- Do not install the AC Master in the same compartment as the batteries. Do not mount the AC Master straight above the batteries because of possible corrosive sulphur fumes.

Before you start

- Be sure that the output of the supplying source (battery) is switched off during installation. Also be sure that no consumers are connected to the battery during installation, to prevent hazardous situations.
- Before installing the AC Master make sure the main switch (figure 1, ref. 1) is set to the OFF position.
- Check that the battery voltage is the same as the input voltage of the AC Master (e.g. 24V battery for a 24V input voltage). Also check that the output voltage satisfies loading requirements

- A DC fuse holder must be integrated in the positive wiring. The DC fuse should be placed last of all.
- Use four $\varnothing 4.5\text{mm}$ (No. 8) screws to mount the AC Master to a solid surface.

Wiring

- Connect DC wiring as shown in figure 2: the black terminal (9) NEG (-) to the negative (-) pole of the power source / battery, the red terminal (8) POS (+) to the positive (+) pole of the power source/ battery. Integrate a DC fuse holder in the positive wiring, but do not place the fuse yet. Assemble the DC wiring exactly as indicated. Do not place anything between the ring terminal and the terminal surface. Make sure that all DC connections are tight. Recommended torque: 11.7-13 Nm / 104-115 InLbs
- Chassis ground: Use a cable AWG8 / 6 mm² to connect the CHASSIS GROUND terminal (7) to the central ground.
 - NOTE: the neutral connector N of the AC output (ref. 2) is NOT connected to the CHASSIS GROUND terminal (ref. 7).
- Remote operation switch (option). If you want to operate the AC Master on a remote location, you can install a switch as indicated in figure 2. When the contact is closed, the AC Master is switched on.

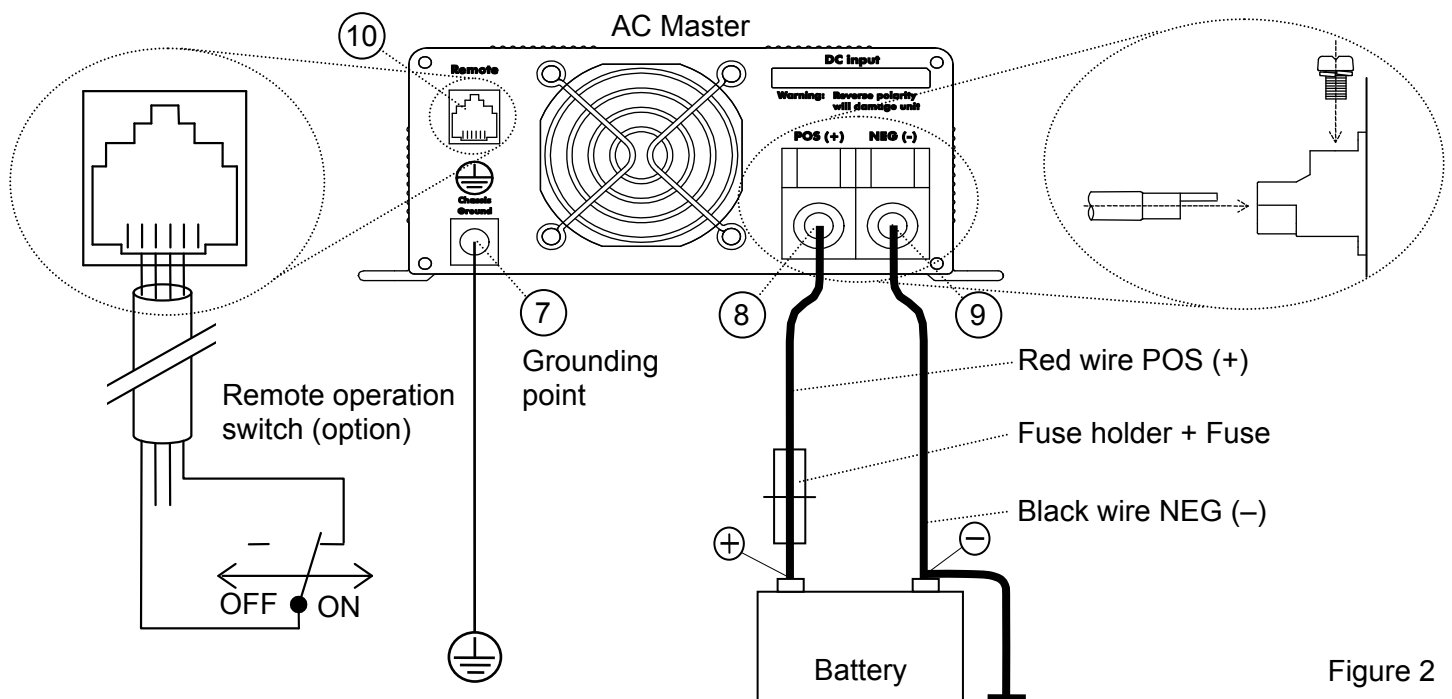

Figure 2

COMMISSIONING AFTER INSTALLATION

1. Check the polarity of the DC-connections. Do not place the DC fuse if the polarity is not correct.
2. Place a DC-fuse (see SPECIFICATIONS) in the fuse holder. When placing this fuse, a spark may occur, caused by internal capacitors of the AC Master. This is normal.
3. AC voltage: the load can be plugged into the AC-output (ref. 2) directly.

OPERATION

Switching on:

Move the main switch (ref. 1) to "ON". The AC Master will start a self-test indicated by two beeps from the buzzer and flashing LED indicators. This may last for approximate two seconds. Finally the buzzer will produce another beep and the AC Master will switch on, indicated by two green LED indicators.. Now the AC Master is ready to supply load connected to the AC-output.

Switching off:

Move the main switch (ref. 1) to the "OFF" position. Note that switching off the AC Master does not break the connection to the batteries!

Remote operation:

The AC Master can be operated on a remote location by means of an optional remote switch. Move the main switch (ref. 1) to the "REMOTE" position. When the remote contact is closed, the AC Master is switched on.

LED indicators

See figure 3. The operation of the inverter is made visible by means of LED indicators (3), (4) and (5).

"INPUT LEVEL" (ref. 3) displays the input voltage of the inverter:

Indication of the LED	Input voltage (V)	
	12/700	24/700
RED blinking slow	10.5~10.9	21.0~21.8
RED	10.9~11.3	21.8~22.6
ORANGE	11.3~12.0	22.6~24.0
GREEN	12.0~14.0	24.0~28.0
ORANGE blinking	14.0~14.7	28.0~29.4
RED blinking fast	> 14.7	> 29.4

"LOAD LEVEL" (ref. 4) shows the output load level:

Indication of the LED	Power level
-none- (LED is off)	0...35W
GREEN	35...230W
ORANGE	230...525W
RED	525...675W
RED blinking	> 675W

"STATUS" (ref. 5) shows the operation mode of the inverter. As long this LED isn't illuminated red, no failure is detected: the inverter is operating normally. If an error occurs, it is detected by the apparatus itself: the "STATUS" LED turns red.

Indication of the LED	Meaning
GREEN, uninterrupted	Power OK
— — — —	Power saving mode, see DIP SWITCH SETTINGS
GREEN, slow blinking	
— — — — — — — —	DC-input voltage too high
RED, fast blinking	
— — — — —	DC-input voltage too low
RED, slow blinking	
- - - - - - - - - -	Internal temperature too high
RED, intermittently blinking	
— — — — — — — — — —	Overload / short circuit
RED, uninterrupted	

Maintenance

No specific maintenance is required. If necessary, use a soft clean cloth to clean the AC Master. Never use any liquids, acids and/or scourers. Check the wiring on a regular base. Defects such as loose connections, burnt wiring etc. must be corrected immediately.

DECOMMISSIONING

Proceed as follows for decommissioning of the inverter:

1. Move the main switch (ref. 1) to the OFF position.
2. Remove the DC fuse. Be sure that others can not reverse this action taken.
3. Now the inverter can be demounted in a safe way.

TROUBLE SHOOTING

Consult an installer, if you cannot solve the problem by means of the table below.

Problem	Possible cause	What to do?
No output voltage, all LED indicators are off	Main switch (ref 1) is set to the OFF position	Set the main switch (ref 1) in ON position
	Main switch (ref 1) is set to REMOTE but no remote present	Set the main switch (ref 1) in ON position
	The remote switch is off (if applied)	Close the remote operation switch
	DC fuse blown	Replace the fuse
No output voltage, STATUS LED (ref 5) is slowly blinking green.	Inverter is in power saving mode	Increase the load or adjust the power setting mode; See DIP SWITCH SETTINGS
No output voltage, STATUS LED (ref 5) is fast blinking red.	DC input voltage too high	Check battery voltage; switch off charger. The inverter will switch on again when the input voltage is <14.2 / <28.4V
No output voltage, STATUS LED is slowly blinking red.	DC input voltage too low (flat battery)	Charge the battery. The inverter will switch on again when the input voltage is >12.5V / >25.0V
No output voltage, STATUS LED is intermittently blinking red.	Too much load connected to the inverter	Reduce the load and let the inverter cool down. The inverter will switch on again when the internal temperature is < 45°C / 113°F
	Airflow insufficient	Check the airflow through the inverter. The operation of the cooling fan may not be blocked.
No output voltage, STATUS LED is uninterruptedly lit red.	Output overloaded or short circuit.	Reduce the load and/or check the AC wiring for possible short circuits. Then reset the inverter manually by switching the main switch off and on again
Inverter switches on and off. STATUS LED is slowly blinking red.	DC input voltage too low because of voltage drop across the DC cables due to too long or too narrow cables	Reduce the length of the DC cables or use cables with a larger gauge.
	Flat battery	Disconnect the load and recharge the battery
	Loose or corroded connections	Tighten the connections; burnt cables must be corrected immediately.
Some loads like televisions and clocks do not operate correctly	Wrong setting of output frequency	Check the specified input frequency of the load with the output frequency of the AC Master. If necessary, adjust the output frequency. See DIP SWITCH SETTINGS.

GUARANTEE TERMS

Mastervolt guarantees that this product was built according to the legally applicable standards and stipulations. During production and before delivery all products are exhaustively tested and controlled. If you fail to act in accordance with the regulations, instructions and stipulations in this user's manual, damage can occur and/or the product will not fulfil the specifications. This may mean that the guarantee will become null and void. The guarantee is limited to the costs of repair and/or replacement of the product by Mastervolt only. Costs for installation labour or shipping of the defective parts are not covered by this guarantee.

For making an appeal on warranty you can directly contact your supplier, mentioning your complaint, application, date of purchase and part number / serial number.

The standard guarantee period is 2 years.

LIABILITY

Mastervolt cannot be held liable for:

- Possible errors in this manual and the consequences of these.
- Use that is inconsistent with the purpose of the product.

SPECIFICATIONS

Model AC Master	12/700-230V EU	24/700-230V EU
Part number:	27510700	27520700
Function of the apparatus:	Conversion of a DC voltage to a pure AC sine wave voltage	
Supplier:	Mastervolt, Amsterdam, the Netherlands	
General		
Input voltage:	12VDC (10.5-15.0VDC)	24VDC (21.0-30.0VDC)
Nom Power $T_{amb}=40^{\circ}C$, $\cos \phi$ 1	700W	700W
Max. peak load	1400W	1400W
Output waveform	True sinewave (THD <3%)	
Maximum efficiency	91%	93%
Output voltage	230V \pm 5%	230V \pm 5%
Frequency (selectable)	50/60 Hz \pm 0.03Hz	50/60 Hz \pm 0.03Hz
AC outlet	Euro power outlet IEC320 (1m/3ft AC-lead with IEC320-plug included)	
Dimensions (LxWxH)	295 x 180 x 72 mm / 11.61 x 7.09 x 2.83 inch	
Weight:	2.7 kg / 5.4 Lbs	2.7 kg / 5.4 Lbs
Protection degree	IP21	IP21
Technical		
Technology	HF / Switch mode	
Shut down voltage low battery	10.5V (\pm 0.5V)	21.0V (\pm 0.5V)
Restart voltage low battery	12.5V (\pm 0.5V)	25.0V (\pm 0,5)
Shut down voltage high battery	15.3V (\pm 0.5V)	30.6V (\pm 0.5V)
Restart voltage high battery	14.2V (\pm 0.5V)	28.4V (\pm 0.5V)
Maximum allowed ripple on DC	5% RMS	
Input current @ nominal load	64A	32A
External DC fuse required	100A	50A
Recommended battery capacity:	>100Ah	>50Ah
DC cable (up to 3m / 10ft)	16mm ² AWG4	10mm ² AWG6
No load power consumption:		
Off mode	0mA	0mA
Power Saving Mode	0.25A	0.15A
ON @ U_{nom}	1.2A	0.6A
Operating temperature specified (will meet specified tolerances)	Full specifications at ambient temperature 0 to 40°C (32 to 104°F), Derating with 5%/°C (3%/°F) at 40 to 60°C (104 to 140°F), Shutdown at over temperature, auto recover after cooling down	
Practical operating temperature (may not meet specified tolerances)	Ambient temperature -25 to 40°C (-13 to 104°F) Derating with 5%/°C (3%/°F) at 40°C to 60°C (104 to 140°F). Shutdown at over temperature, auto recover after cooling down	
Cooling:	Temperature and load regulated fan	
Non-operating temperature (storage temperature)	Ambient temperature -30°C to 70°C / -22°F to 158°F	
Relative humidity	Protected against humidity and condensing air by conformal coating on both sides of all PCB's. Max 95% relative humidity, non-condensing.	
Safety:	EN 60950-1	
EMC	EN55022, EN61000-3-2, EN61000-3-3, EN55024	
Protections		
Protections:	Overload, short circuit, over / under voltage, over temperature	
Reversed polarity:	Internal fuse, reversed polarity may lead to permanent damage	

DIMENSIONS

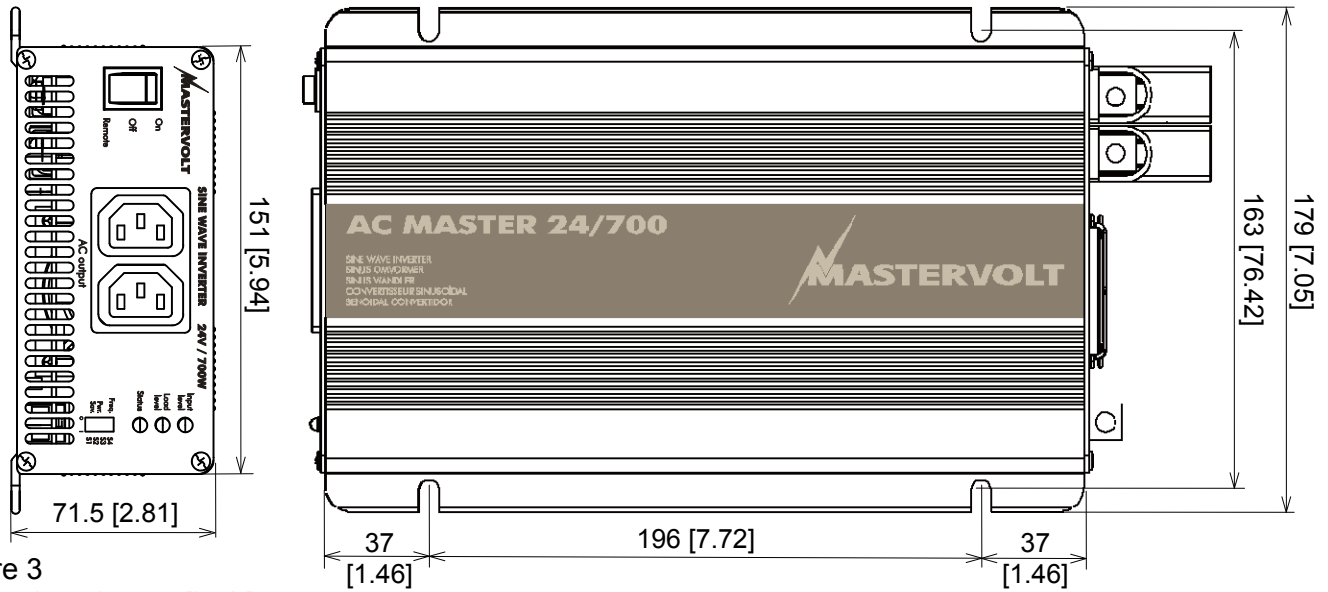

Figure 3
Dimensions in mm [inch]

EC DECLARATION OF CONFORMITY

Supplier: Mastervolt
 Address: Snijdersbergweg 93, 1105 AN Amsterdam , The Netherlands
 Herewith declares that product:



- 27510700 AC Master 12/700 230V/50Hz EU
- 27520700 AC Master 24/700 230V/50Hz EU

Is in conformity with the provision of the EC EMC directive 89/336/EEC and amendments 92/31/EEC, 93/68/EEC.

The following harmonised standards have been applied:

- Generic emission standard: EN 55022: 1998+A1: 2000+A2: 2003
- Generic Immunity standard: EN 55024: 1998+A1: 2001+A2: 2003
- Harmonic current emissions: EN 61000-3-2: 2000
- Fluctuations and flicker: EN 61000-3-3: 1995 + A1: 2001

Safety directive 73/23/EEC and amendment 93/68/EEC, with the following standard:
 Low voltage standard: EN 60950: 2000

Amsterdam,

P.F. Kenninck,
 General Manager MASTERVOLT

